



More Precision.

3D sensors for precise inline quality inspection



Precise raw data for integrators



Precise raw data for integrators and image processors

The 3D sensors from Micro-Epsilon are used for a variety of measurement and inspection tasks on both matt and shiny surfaces. The results can be documented and compared. This allows for important conclusions to be drawn for process improvements. All 3D inspection systems from Micro-Epsilon can be used in offline applications as well as in fully automated operation and on the robot.

Software integration via Micro-Epsilon's 3D-SDK

3D sensors from Micro-Epsilon are equipped with a user-friendly SDK (Software Development Kit). The SDK is based on the GigE Vision and GenICam industry standards including the following essential function blocks:

- Network configuration and sensor connection
- Control of data transmission (3D measurement data, video images, profile counters, ...)
- Comprehensive sensor control
- User sets
- Documentation
- C++ example programs
- 3D Viewer

3D SDK at a glance:

- For the integration of all 3D sensors
- GigE Vision / GenICam compatible
- Access to all sensor parameters
- Examples included
- Comprehensive documentation



Powerful software for 3D measurement tasks

3DInspect

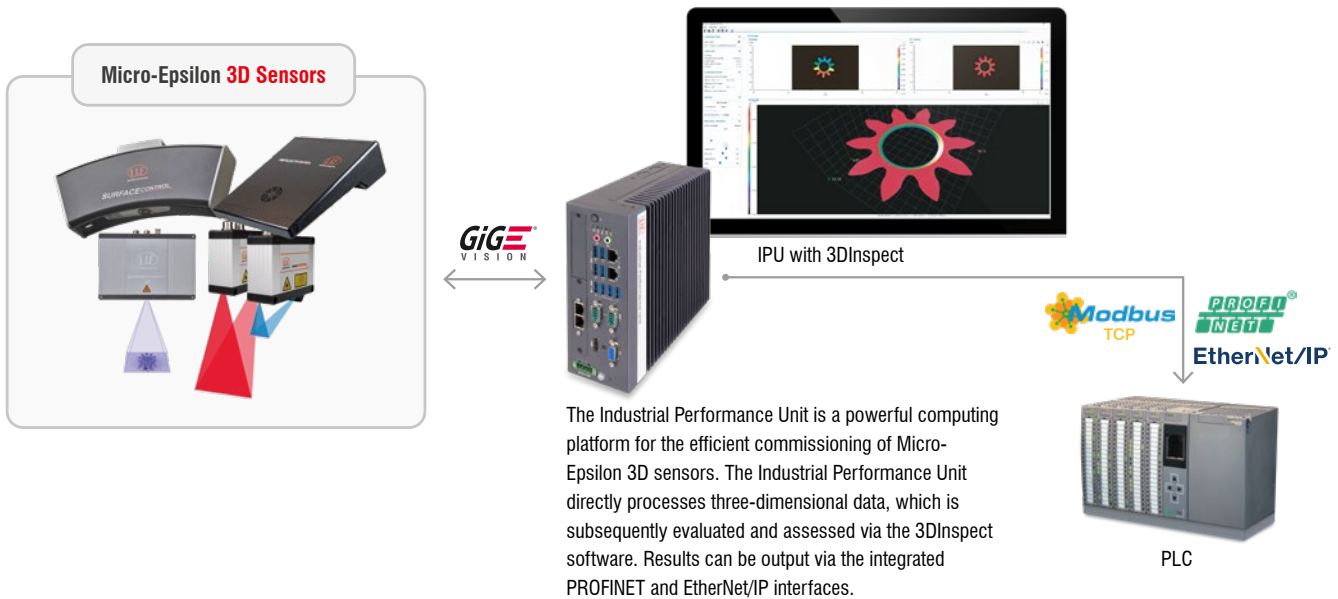

3DInspect is a uniform and user-friendly software tool for all 3D sensors from Micro-Epsilon. Parameter setting of the 3D sensors and recording of the measurement data are done directly in the 3DInspect software. Powerful tools allow point cloud alignment and filtering, intuitive detection and selection of relevant areas, and program combination. The 3D point clouds can be processed as required and measured values can be output to the controller.

3DInspect at a glance:

- One software for all 3D sensors
- High compatibility
- High flexibility
- Intuitive user interface
- Real 3D evaluation, not just 2.5D
- Object extraction in 3D
- Direct feedback with algorithms

Data acquisition

Data preprocessing

Evaluation

Results

3DInspect uses a logical program structure that proceeds step-by-step from data acquisition through processing to outputs and results.

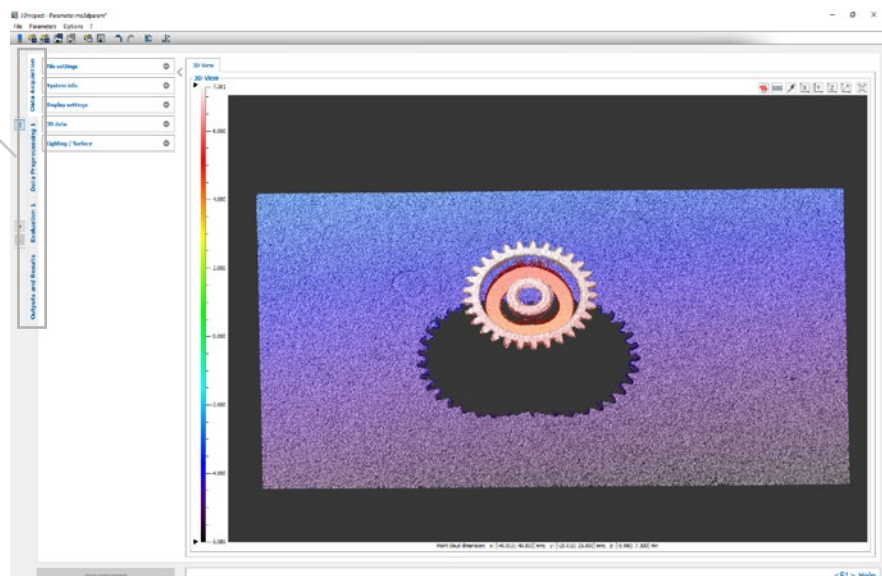

Software for 3D measurement and inspection tasks

3DInspect

Intuitive user interface

Real 3D evaluation, not just 2.5D

Object extraction in 3D

Direct feedback with algorithms

Compatible with all 3D sensors from Micro-Epsilon

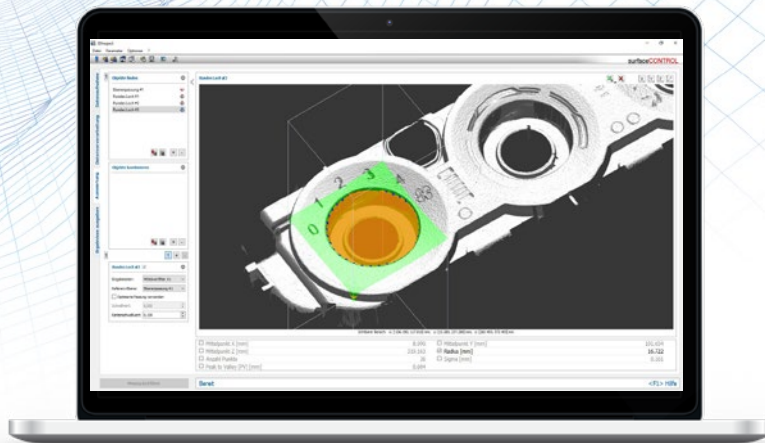

The 3DInspect software is a powerful tool for sensor parameter set up and industrial measurement tasks. This software transmits the measurement data from the sensor via Ethernet and provides the data in three-dimensional form. This 3D data is further processed, evaluated and assessed with 3DInspect measuring programs on the PC and, if necessary, logged and transmitted via Ethernet to a control unit. Furthermore, the software enables the storage of 3D data. The 3DInspect software supports the scanCONTROL 30xx models as well as the surfaceCONTROL and reflectCONTROL 3D sensors.

Valid3D technology from Micro-Epsilon vs. conventional 2.5D systems

The unique Valid3D technology enables lossless display and processing of the point clouds. This is how scanned 3D objects can be moved arbitrarily in the coordinate system.

Valid3D: Real 3D without data loss

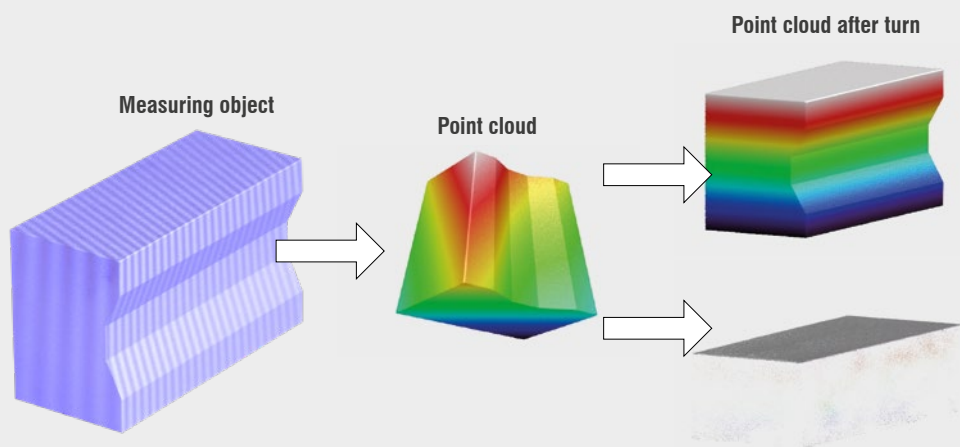

3DInspect with Valid3D

- Real 3D image of test object without data loss
- Analysis and evaluation of complete test object

Common 3D software

- Algorithms based on 2.5D
- Only one z-coordinate per x/y coordinate possible
- Data loss during data processing

Data preprocessing

In data preprocessing, the point cloud can be adjusted before evaluation. This enables, for example, the correction of a changing component position, so that the point cloud for the evaluation is always in the same position.

In addition, it is possible to refine the point cloud before evaluation, to apply filters to highlight features, to cut away irrelevant points or to set sections.

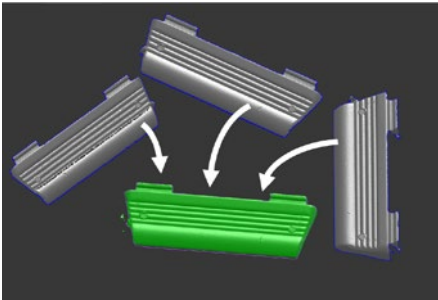

Automatic alignment of the point cloud

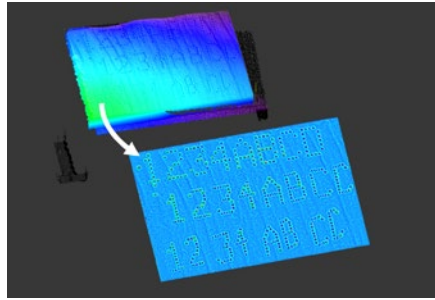

Processing of data

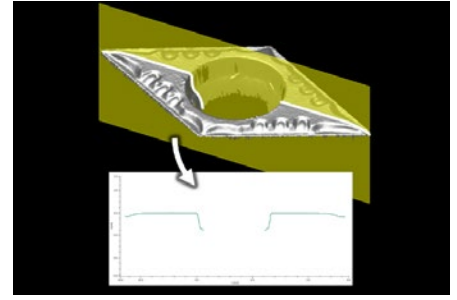

Setting cuts

Data evaluation

For data analysis, numerous programs are available to locate and measure characteristics. These can be edges, spheres or holes, for example. Both the evaluation of the 3D data, and a measurement or evaluation directly in previously generated sections is possible.

The 2D and 3D objects can also be set in relation to each other using combinations, for example to determine distances between a sphere and a plane or the angle between two edges.

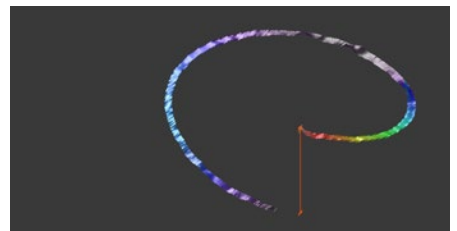
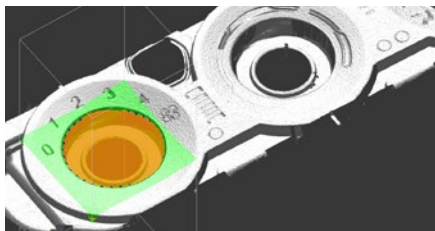
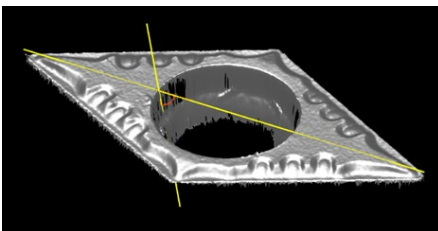
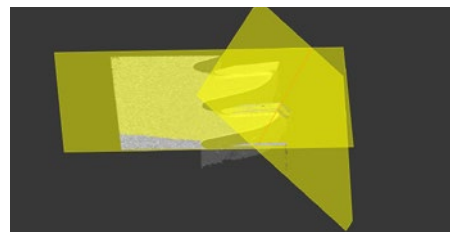
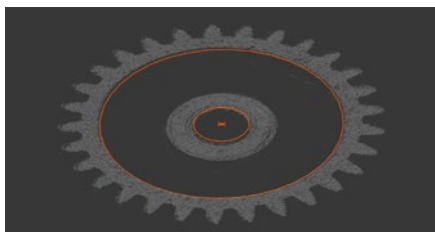
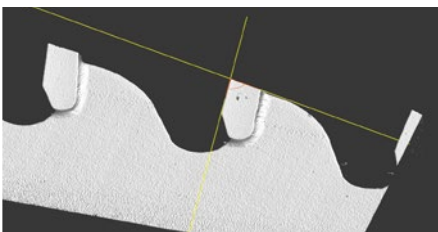
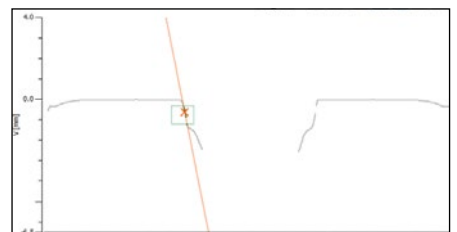
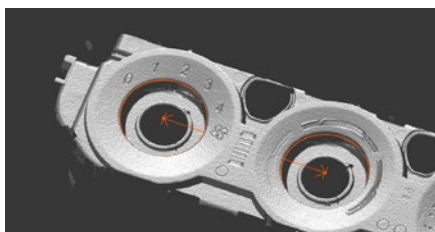
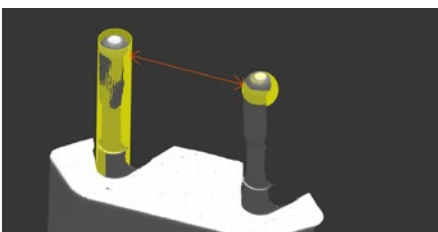
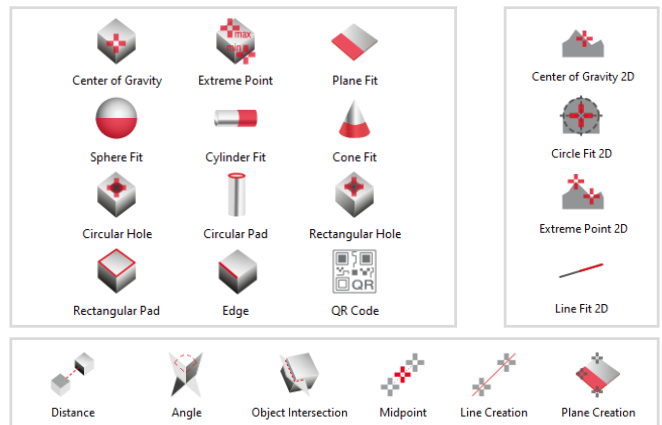

Laser scanners for 3D profile measurement

scanCONTROL

Up to 2,048 points per profile

Up to 7,372,800 points per second

Compact size

High lateral resolution from $7.8 \mu\text{m}$

Small and compact, ideal for robotic applications

Available with red and blue laser line

GigE Vision standard – easy to integrate into common image processing software



scanCONTROL laser line scanners use the laser triangulation principle for two-dimensional profile detection on different target surfaces. Line optics project a laser line onto the target surface. A high-quality optical system images the diffusely reflected light from this laser line onto a sensor matrix. From this camera image, the controller calculates the distance information (z-axis) and the position alongside the laser line (x-axis) and outputs both in a two-dimensional coordinate system. In the case of moving objects or traversing the sensor, a 3D point cloud is obtained from the juxtaposition of the profiles.

Assignment of the exact position of the sensor relative to the position of the measured object can be carried out via the integrated encoder inputs. The scanCONTROL laser line scanners have an Ethernet/GigE Vision connection and can therefore be integrated into a wide variety of image processing packages up to 3D evaluation. A device driver including sample VIs is available for LabVIEW users. Furthermore, integration into Linux is possible.

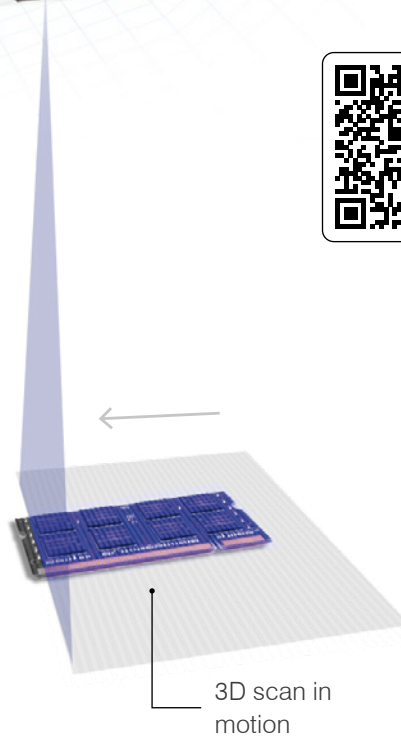

High precision 3D scans

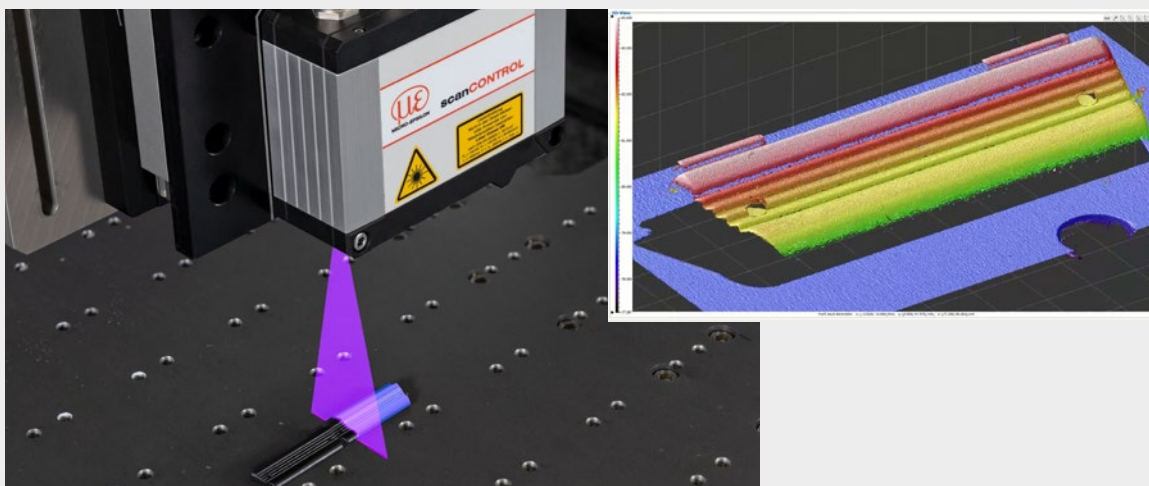

Model		LLT30x0-25	LLT30x0-50	LLT30x0-100	LLT30x0-200	
Available laser type		Red Laser Blue Laser	Red Laser Blue Laser	Red Laser Blue Laser	Red Laser	
z-axis	Measuring range	Start of measuring range	77.5 mm	105 mm	200 mm	200 mm
		Mid of measuring range	85 mm	125 mm	270 mm	310 mm
		End of measuring range	92.5 mm	145 mm	340 mm	420 mm
		Height of measuring range	15 mm	40 mm	140 mm	220 mm
	Extended measuring range	Start of measuring range	-	-	190 mm	160 mm
		End of measuring range	-	-	360 mm	460 mm
	Max. deviation of a single point ¹⁾ (2 sigma)	Red Laser	±0.07 %	±0.07 %	±0.06 %	±0.10 %
	Blue Laser	±0.06 %	±0.06 %	±0.05 %	-	
Line linearity ¹⁾²⁾		1.5 μm	3 μm	9 μm	26 μm	
		±0.01 %	±0.0075 %	±0.006 %	±0.012 %	
x-axis	Measuring range	Start of measuring range	23.0 mm	43.3 mm	75.6 mm	130 mm
		Mid of measuring range	25.0 mm	50.0 mm	100 mm	200 mm
		End of measuring range	26.8 mm	56.5 mm	124.4 mm	270 mm
	Extended measuring range	Start of measuring range	-	-	72.1 mm	100 mm
		End of measuring range	-	-	131.1 mm	290 mm
Resolution		2,048 points/profile				
Profile frequency		Up to 10,000 Hz				
Interfaces	Ethernet GigE Vison	Sensor control Profile data transmission				
	digital inputs	Mode switching Encoder (counter) Trigger				
	RS422 (half-duplex) ³⁾	Sensor control Trigger Synchronization				

¹⁾ Based on the measuring range; measuring object: Micro-Epsilon standard object

²⁾ According to a one-time averaging over the measuring field (2,048 points)

³⁾ RS422 interface, programmable either as serial interface or as input for triggering/synchronization

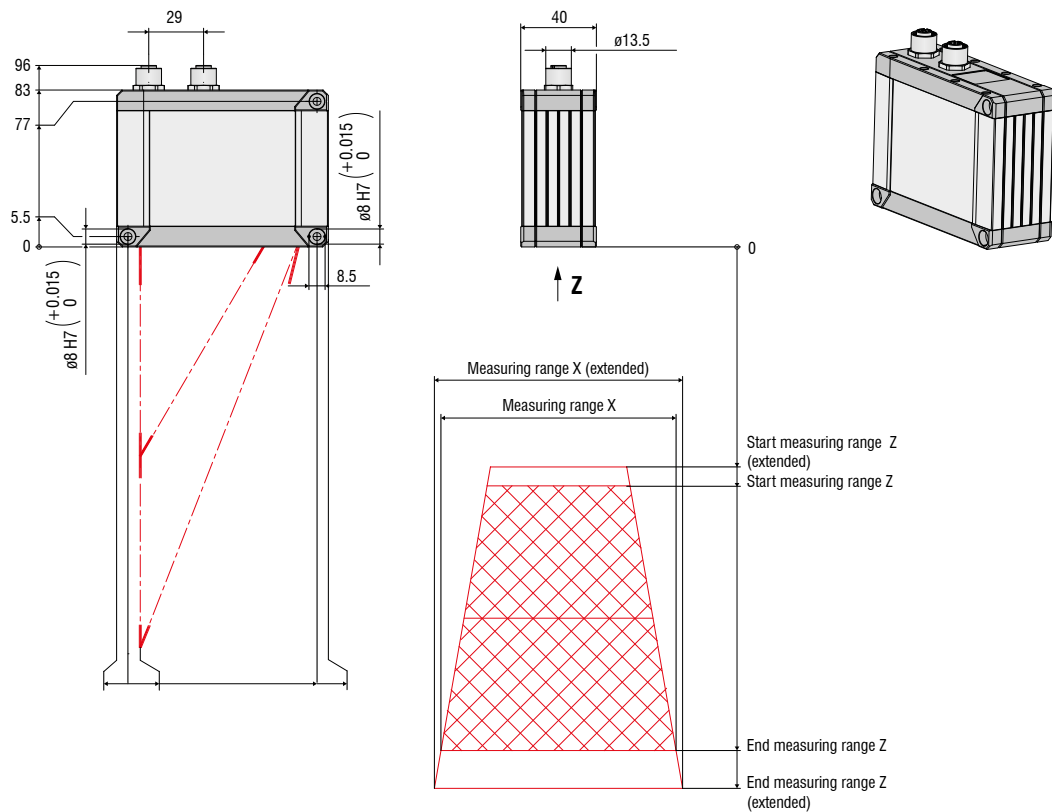

High precision 3D sensors for inline shape and surface inspection

surfaceCONTROL 3D 3500

Highest repeatability up to $0.4 \mu\text{m}$

Best Z-axis resolution from $1.0 \mu\text{m}$

Up to 2.2 million 3D points / second

Easy integration in all common 3D image processing packets



The new generation of high precision inline 3D measurements

The high precision 3D snapshot sensor surfaceCONTROL 3D 3500 sensor is ideally suited to automated inline inspection of geometry, shapes and surfaces on diffuse reflecting surfaces. The sensor works according to the principle of fringe projection, which allows direct 3D measurement. The surfaceCONTROL 3D 3500 stands out due to its compact design and high measurement accuracy combined with high data processing speed. With a z-axis repeatability of up to $0.4 \mu\text{m}$, the sensor sets new standards in high precision 3D metrology. This enables reliable detection of even the smallest deviations in flatness and height. Two models cover different measuring fields.

In addition to the fast data output via Gigabit Ethernet, the sensor offers an additional digital I/O interface. The 2D/3D Gateway II supports EtherNet/IP, PROFINET and EtherCAT connections. Powerful software tools enable precise 3D measurements and surface inspection. GigE Vision compatibility also allows easy integration into third-party image processing software. The comprehensive SDK for customer software integration rounds off the software package.

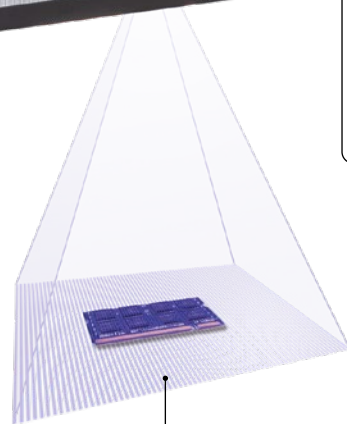

3D snapshot

High precision 3D snapshots

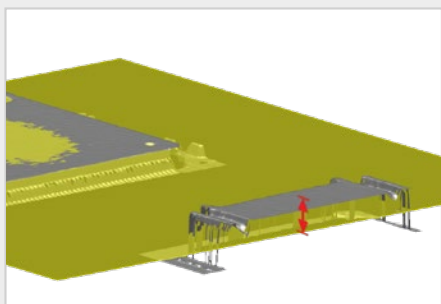

Monitoring of distance and plane-parallelism of assembled elements to each other and to the base surface (e.g. tombstone effect)

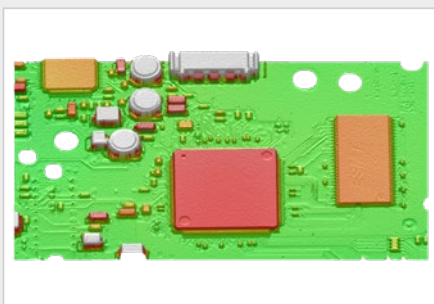

Completeness check of electronic components on fitted PCBs

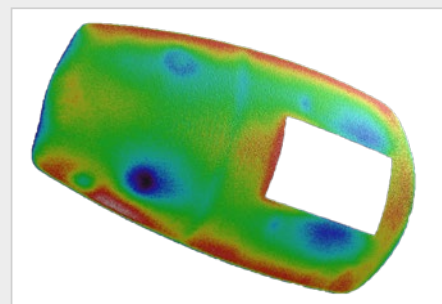

Determination of shape deviation defects on the front side of injection-molded parts caused by injection of bridges and joining elements on the rear side

Model	surfaceCONTROL 3D	SC3500-80	SC3510-80	SC3500-120	SC3510-120
Measurement area Length (x) * width (y) at distance (z)	Start of expanded area	55 mm x 42 mm at 110 mm		87.5 mm x 62.5 mm at 171 mm	
	Start	67.5 mm x 46 mm at 120 mm		107.5 mm x 70 mm at 191 mm	
	Mid	80 mm x 50 mm at 130 mm		120 mm x 75 mm at 206 mm	
	End	77.5 mm x 52 mm at 140 mm		123.5 mm x 80 mm at 221 mm	
	End of expanded area	75 mm x 54 mm at 150 mm		122 mm x 82.5 mm at 241 mm	
Working distance	z	130 ± 10 mm		206 ± 15 mm	
	extended z	130 ± 20 mm		206 ± 35 mm	
Resolution	x, y	40 μm		60 μm	
	z ¹⁾	1.0 μm		2.0 μm	
Repeatability	z (σ) ¹⁾	< 0.4 μm		< 0.8 μm	
Acquisition time ^{2) 3)}		0.2 ... 0.4 s			
Light source		LED			
Supply voltage		24 VDC ± 20 %			
Maximum power consumption		0.5 ... 2.5 A			
Digital interfaces		Gigabit Ethernet (GigE Vision / GenICam) / PROFINET ⁴⁾ / EtherCAT ⁴⁾ / EtherNet/IP ⁴⁾			
Digital in-/outputs		4 digital I/Os for which parameters can be set (for external trigger, sensor control, output of sensor states)			
Connector		8-pin M12 socket for Gigabit Ethernet, 12-pin M12 socket for digital I/Os, 4-pin M12 plug for power supply			
Assembly		3 mounting holes (installation can be reproduced with centering sleeves)			
Temperature range	Storage	-20 ... +70 °C			
	Operation ⁵⁾	0 ... +45 °C			
Shock (DIN EN 60068-2-27)		15 g / 6 ms in XY axis, 1000 shocks each			
Vibration (DIN EN 60068-2-6)		2 g / 20 ... 500 Hz in XY axis, 10 cycles each			
Protection class (DIN EN 60529)		IP67			
Material		aluminum housing, passive cooling; external cooling optionally available (see accessories)			
Weight		1.9 kg			
Control and indicator elements		3 LEDs (for device status, power, data transmission)			
Sensor SDK		Micro-Epsilon 3D sensor SDK			
3D evaluation software		Micro-Epsilon 3DInspect			
Functional extension		-	3DInspect Automation	-	3DInspect Automation

¹⁾ Measured on measuring object with cooperative surface in the center of the measurement area while the EnhancedSNR parameter is enabled and a 3x3 mean value filter is used once at a consistent room temperature of (20 ± 1 °C).

²⁾ Duration that the sensor requires for the image acquisition of the pattern projections (without processing and evaluation time).

³⁾ Applies for exposure times < 6,800 μs

⁴⁾ Connection via 2D/3D gateway interface module

⁵⁾ Max. permissible operating temperature depends on installation scenario, connection and operating mode.

If necessary, external heat dissipation must be implemented to ensure that the sensor's internal temperature of 60 °C is not exceeded.

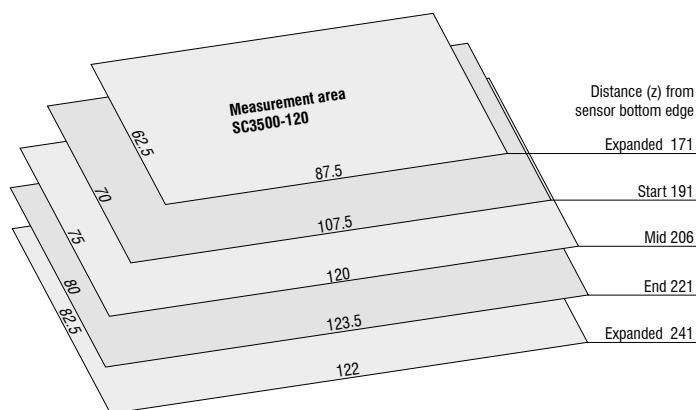
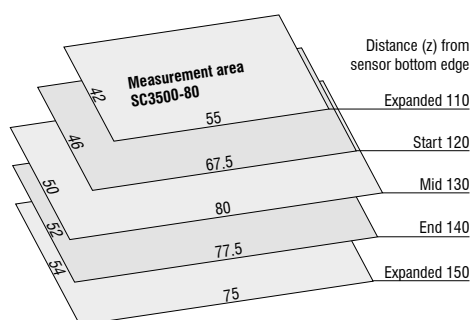
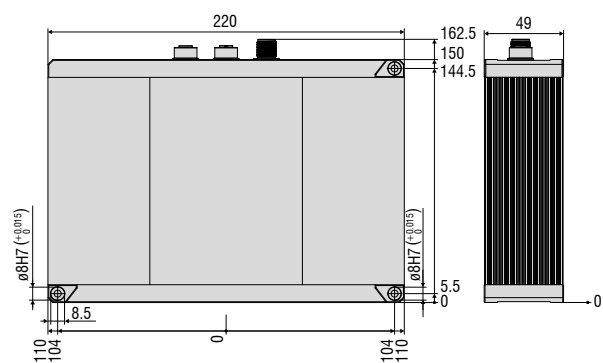

Sensor for inspection of large surfaces

surfaceCONTROL 3D 2500

Inspection of large objects

High measuring range depth up to 300 mm

Acquisition time from 0.5 seconds

Z-axis repeatability up to 3.0 μm

Automated inline 3D measurement for geometry, shape and surface inspections

Real 3D data via latest 3D GigE Vision standard

3D snapshot sensor for surface inspection of large objects

The surfaceCONTROL 3D sensors are ideally suited to automated inline inspection of geometry, shapes and surfaces on diffuse reflecting surfaces. The 3D snapshot sensors work according to the principle of fringe projection, which allows direct 3D measurement of components. The sensor is characterized by a large measuring field as well as a high measuring range depth with a z-axis repeatability of up to 3.0 μm . Three models cover different measuring fields.

The captured images are first transferred to the external controller, where they are processed into 3D data. The SC2500 controller offers fast data output via Gigabit Ethernet. The 2D/3D Gateway II supports EtherNet/IP, PROFINET and EtherCAT connections. 3DInspect, DefMap3D and InspectionTools are powerful software tools that enable precise 3D measurements and surface inspection. GigE Vision compatibility also allows easy integration into third-party image processing software. The comprehensive SDK for customer software integration rounds off the software package.

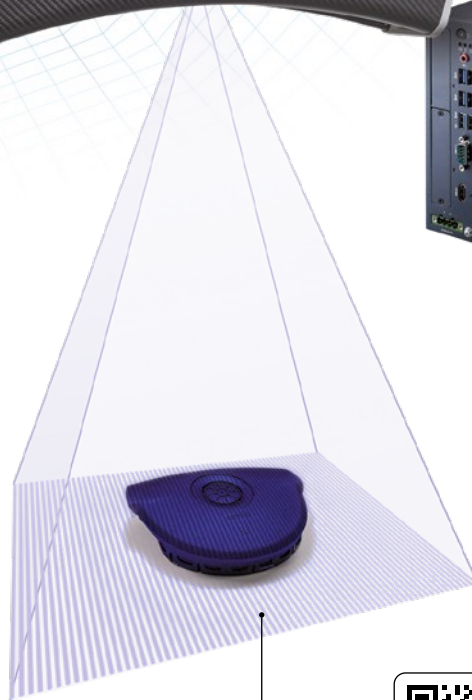

High precision 3D snapshots

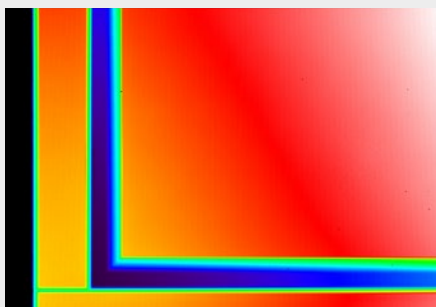

Shape defects on furniture boards

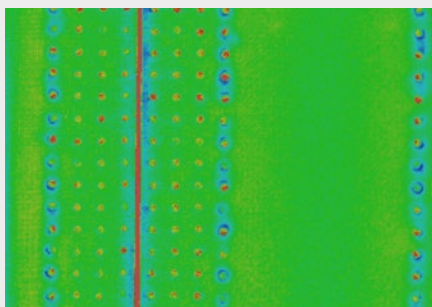

Rivet inspection: deformation, height and position of the rivet

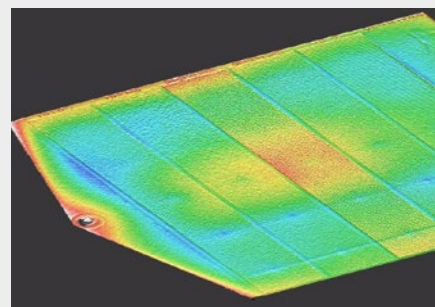

Sink mark on injection molded components

Model	surfaceCONTROL 3D	SC2500-300	SC2510-300	SC2500-400	SC2510-400	SC2500-575	SC2510-575
Measurement area Length (x) * width (y) at distance (z)	Start	260 mm x 190 mm at 475 mm		350 mm x 260 mm at 660 mm		500 mm x 375 mm at 950 mm	
	Mid	300 mm x 220 mm at 550 mm		400 mm x 300 mm at 760 mm		575 mm x 435 mm at 1100 mm	
	End	340 mm x 250 mm at 625 mm		450 mm x 340 mm at 860 mm		650 mm x 495 mm at 1250 mm	
Working distance	z	550 ± 75 mm		760 ± 100 mm		1100 ± 150 mm	
Resolution	x,y	250 μm		300 μm		500 μm	
	z ¹⁾	8.5 μm		12.7 μm		24 μm	
Repeatability	z _(σ) ¹⁾	< 3.0 μm		< 4.5 μm		< 8.5 μm	
Acquisition time ^{2) 3)}				0.5 ... 1 s			
Light source				LED			
Supply voltage				18 VDC ± 33 %			
Maximum power consumption				6 ... 12.5 A			
Connector		8-pin M12 socket for Gigabit Ethernet camera 1, connection to controller, 8-pin M12 socket for Gigabit Ethernet camera 2, connection to controller, 4-pin LEMO push-pull plug for sensor control (USB), connection to controller, 2-pin LEMO push-pull plug for supply voltage					
Assembly		Mounting via flange adapter (see accessories)					
Temperature range ⁴⁾	Storage	-10 ... +50 °C, non-condensing					
	Operation	+5 ... +40 °C					
Shock (DIN EN 60068-2-27)		15 g / 6 ms in XY axis, 1000 shocks each					
Vibration (DIN EN 60068-2-6)		2 g / 20 ... 500 Hz in XY axis, 10 cycles each					
Protection class (DIN EN 60529)		IP40					
Material		Carbon, aluminum					
Weight		7.0 kg (without controller)					
Control and indicator elements		2 LEDs on each camera (for device status, power, data transmission)					
Sensor SDK		Micro-Epsilon 3D Sensor-SDK					
3D evaluation software		Micro-Epsilon 3DInspect					
Functional extension		-	3DInspect Automation	-	3DInspect Automation	-	3DInspect Automation
Surface analysis software (optional)		surfaceCONTROL DefMap3D					

¹⁾ Measured on measuring object with cooperative surface in the center of the measurement area while the EnhancedSNR parameter is enabled and a 3x3 mean value filter is used once at a consistent room temperature of (20 ± 1 °C).

²⁾ Duration that the sensor requires for the image acquisition of the pattern projections (without processing and evaluation time).

³⁾ Applies for exposure times < 25 ms

⁴⁾ According to technical data

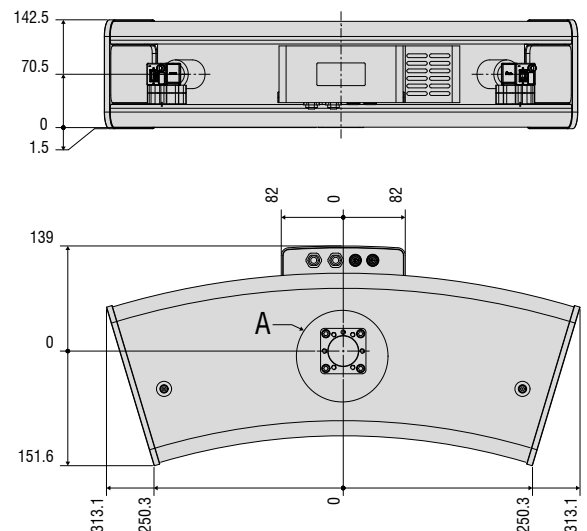
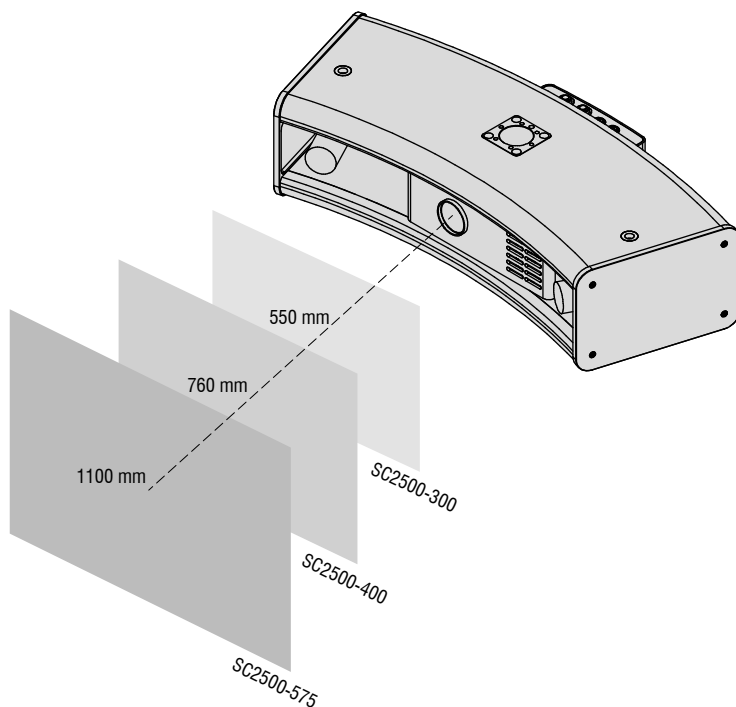

Sensor for high resolution inspection of shiny surfaces

reflectCONTROL Sensor

Reliable detection of the smallest details
 $< 1 \mu\text{m}$

Inspection rate < 2 seconds
 per measuring position

Stationary or robot-based inspection

Software connection via Micro-Epsilon 3D-SDK
 based on GigE Vision and GenICam



3D snapshot

Surface inspection of shiny components

reflectCONTROL is intended for surface inspection of shiny objects. This compact sensor displays a striped pattern which is mirrored by the surface of the measuring object into the sensor cameras. Deviations on the surface will cause deviations from this striped pattern, which are evaluated by software.

Robot-guided measurement

The compact deflectometry sensor can be integrated as a stationary system or guided over the measuring object by a robot. The localized deviations and defects are evaluated and displayed in CAD data.

Application examples:

- Automotive industry: attachments such as bumper and interior parts
- Electronics industry: tablet PCs, display glasses, etc.

High precision 3D snapshots

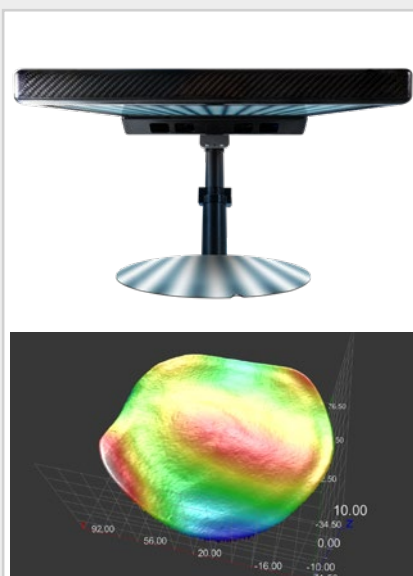

3D shape measurement of wafers

reflectCONTROL sensors exactly detect the wafer's shape in semiconductor production.

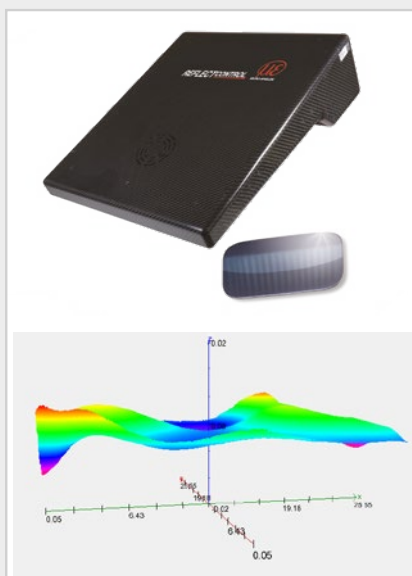

Surface inspection of painted attachments

The smallest surface defects below $1 \mu\text{m}$ are precisely and reliably detected by the reflectCONTROL system.



Precise inspection of flat glass

The reflectCONTROL system is used for the quality inspection of flat glass, e.g., in smartphone production.

Model		RCS130-160	RCS110-245
Measurement area Length x width (x * y) ¹⁾	in reference plane	170 mm x 160 mm	116 mm x 245 mm
Acquisition of measurement data		approx. 1.2 s ... 6 s	approx. 0.6 s ... 2.7 s
Evaluation		approx. 2 s ... 8 s	approx. 0.5 s ... 2.4 s
Resolution	x, y	100 μm	70 μm
Flatness deviation	z ²⁾	< 1 μm	-
Supply voltage		24 V DC (must not exceed 26 V)	
Power consumption		< 50 W	
Interfaces and connections		1 x GigE Vision (RJ45), 1 x Ethernet (RJ45), power supply (3-pin Lemo connector)	
Assembly		mechanically reproducible adapter flange	
Temperature range	Storage	-10 ... +60 °C	
	Operation ²⁾	0 ... +40 °C (for 3D measurements: max. fluctuation of ±2 °C after referencing)	0 ... +40 °C
Humidity ²⁾		10 ... 80 %, non-condensing (for 3D measurements: max. fluctuation of ±2 °C after referencing)	10 ... 80 %, non-condensing
Design		carbon housing with controlled fan, design with integrated controller	
Weight		< 7 kg	

¹⁾ Size specifications refer to the reference plane. Trapezoidal measuring field - the medium width is specified. For exact dimensions see figure.

²⁾ Measured after referencing with a plane mirror (Ø 300 mm) and a flatness of $\lambda/10$ at a max. distance tolerance of ± 0.1 mm.

After referencing, a maximum temperature fluctuation of ± 2 °C and change of humidity of ± 2 % are to be complied with.

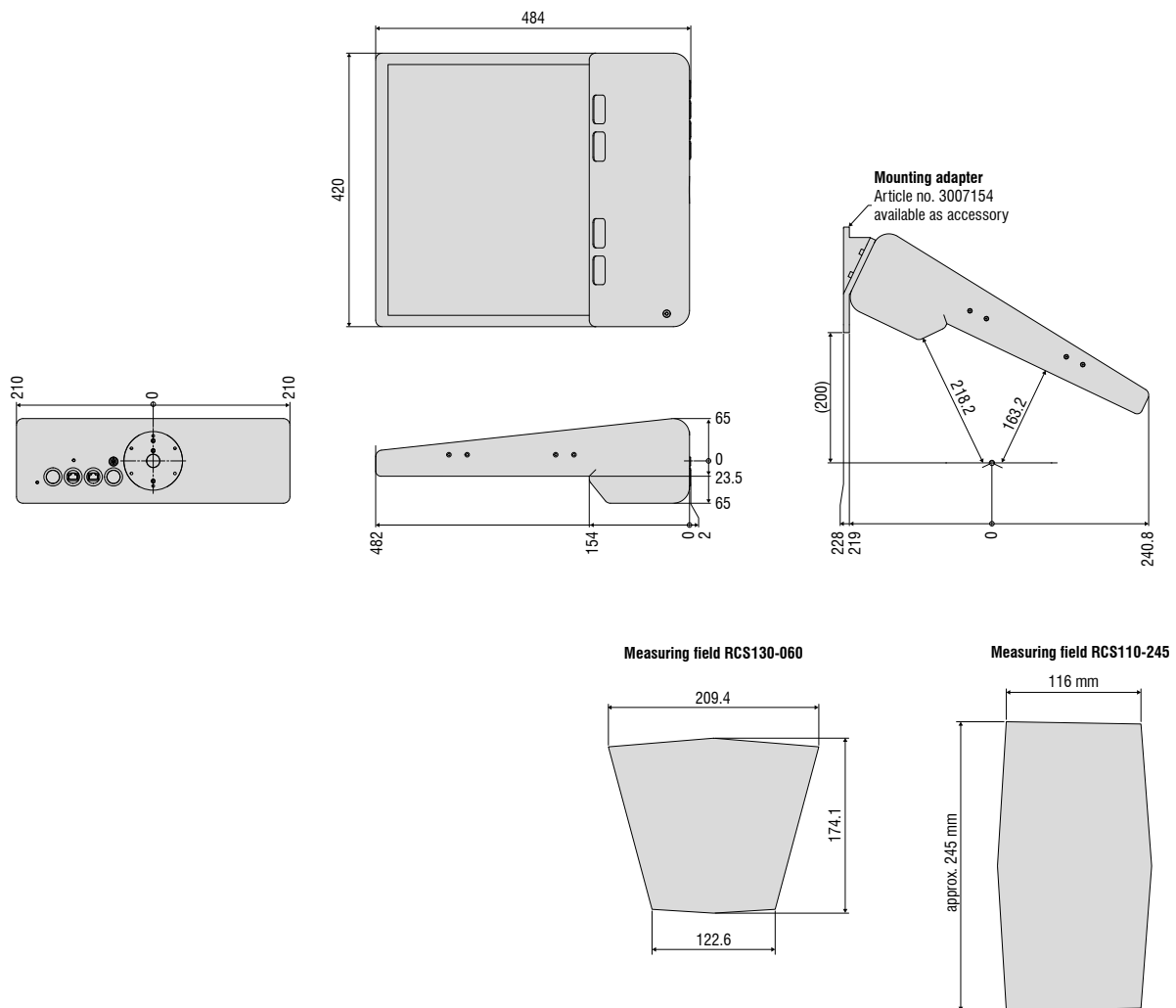

Industrial PC for GigE Vision Sensors

Industrial Performance Unit

High-performance solution for 3D measurement tasks

Full compatibility and inline capability for customer applications

Intuitive 3DInspect software with Valid3D technology by Micro-Epsilon

Efficient commissioning of Micro-Epsilon sensors

Integrated interfaces: Modbus/TCP, PROFINET, EtherNet/IP

Industrial-grade hardware with passive cooling



The powerful solution for 3D measurement tasks

The Industrial Performance Unit is a powerful computing platform for the efficient commissioning of Micro-Epsilon sensors and systems, which offers full compatibility for inline processes in customer applications.

You can connect Micro-Epsilon 3D sensors to the Industrial Performance Unit via the GigE Vision standard. The intuitive 3DInspect software with Valid3D technology from Micro-Epsilon enables simple sensor parameter setting, which allows measurements to start immediately. The Industrial Performance Unit directly processes three-dimensional data, which is subsequently evaluated and assessed via the 3DInspect software. Results can be output via the integrated Modbus/TCP, PROFINET and EtherNet/IP interfaces. In addition, using a gateway enables EtherCAT.

The flexible, industrial-grade hardware with passive cooling allows easy and space-saving installation. This makes integration in a control cabinet or directly in the machine very easy. You can easily connect accessories such as monitor, mouse and keyboard.



3DInspect: Powerful software for all Micro-Epsilon 3D sensors included in the scope of delivery

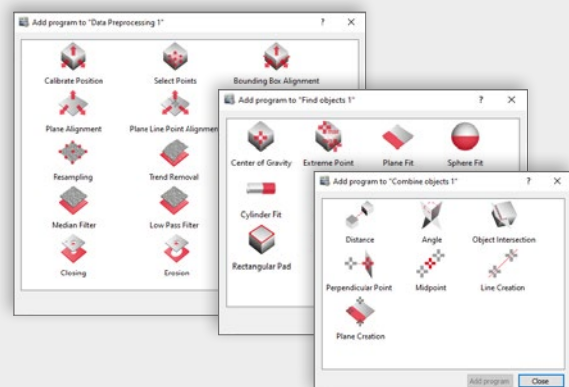
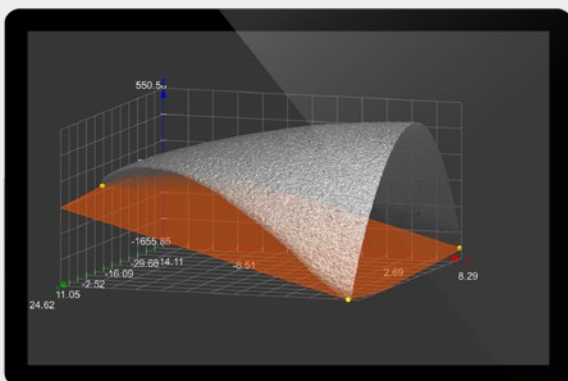

Model	Industrial Performance Unit	
RAM	16 GB	
Memory	128 GB SSD	
Supply voltage	9 ... 36 V DC	
Power consumption	typ.	50 W
	max.	112 W
Digital interfaces	Gigabit Ethernet (GigE Vision / GenICam) / PROFINET / EtherNet/IP	
Connector	4-pin supply terminal strip; 2x RJ45 for Gigabit Ethernet; 2x RJ45 for Industrial Ethernet (PROFINET or EtherNet/IP); 1x HDMI, 1x VGA, 4x USB3.2 (Gen1); 4x USB2.0	
Assembly	Mounting holes; accessories for table or wall mounting and DIN rail mounting	
Temperature range	Storage	-40 ... +85 °C
	Operation ¹⁾	0 ... +50 °C
Shock (DIN EN 60068-2-27)	20 g / 11 ms half-sine	
Vibration (DIN EN 60068-2-6)	3 g / 5 ... 500 Hz	
Protection class (DIN EN 60529)	IP40	
Material	Metal housing	
Weight	2.8 kg	
Control and indicator elements	2 LEDs for storage and power; 4 LEDs for status display of Ethernet 1 power on/off switch	
Special features	Windows 10 IoT Enterprise	

¹⁾ Max. permissible operating temperature with 0.7 m/s air blow

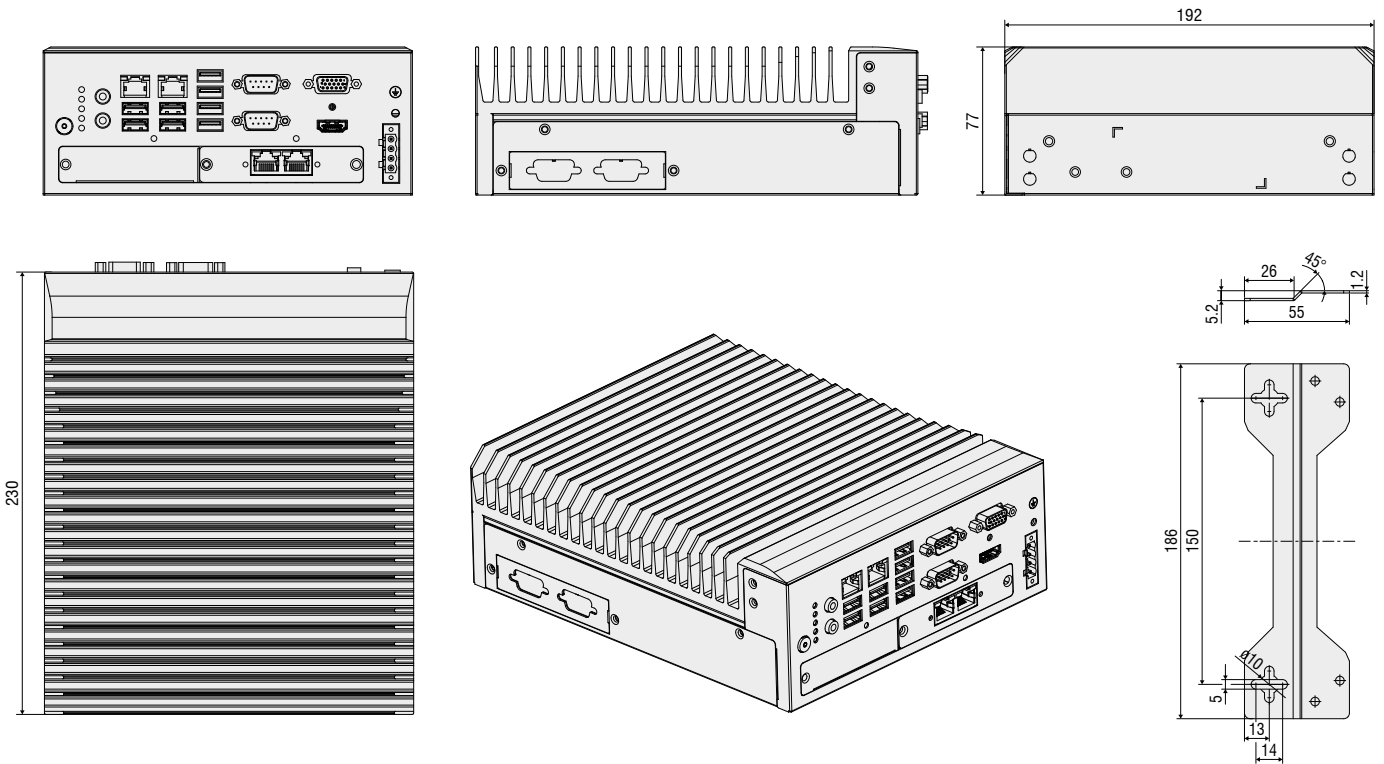

Two mounting rails for table and wall mounting are included in delivery

Sensors and Systems from Micro-Epsilon



Sensors and systems for displacement, distance and position



Sensors and measurement devices for non-contact temperature measurement



Measuring and inspection systems for metal strips, plastics and rubber



Optical micrometers and fiber optics, measuring and test amplifiers



Color recognition sensors, LED analyzers and inline color spectrometers



3D measurement technology for dimensional testing and surface inspection